



Overview

Cooke Brothers

Products

Phoenix Tooling

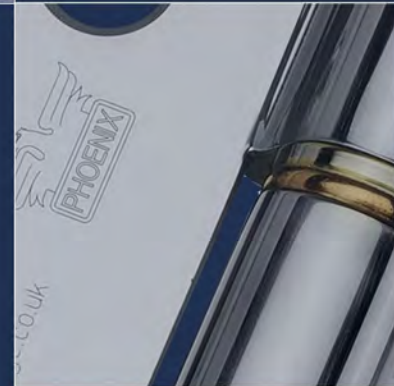
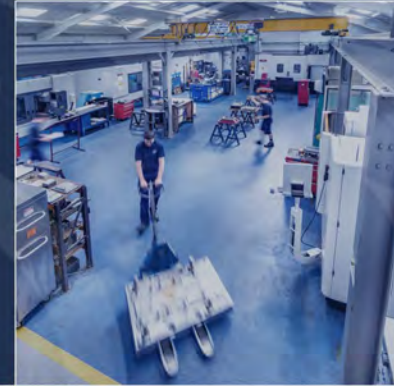

# Overview

## The Company

- Hinge makers since 1872
- Family owned
- Extensive and respected product range
- Substantive in house engineering capability
- Bespoke manufacturing service



Phoenix 1872  
Holding Company



Cooke Brothers Ltd  
Master Hinge Makers



Phoenix Tooling &  
Development Ltd  
Precision Toolmakers



# Cooke Brothers History

Master Hinge Makers –  
Established 1872

Cooke Brothers was established in 1872 when the sons of a Lancastrian cotton producer began manufacturing brass cabinet fittings in the Jewellery Quarter of Birmingham. Today, nearly 150 years later, Cooke Brothers is run by 4th and 5th generations of the Cooke family, in a modern UK based manufacturing facility. The business continues to innovate and lead with British made specialist hinges and ironmongery, as well as wider production capabilities and world sourced products.

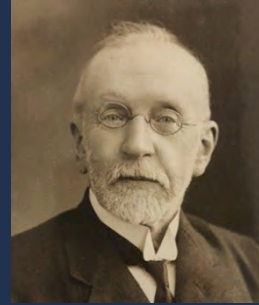

William Edward  
Cooke  
1st generation



Harold Cooke  
2nd generation



Norman Cooke  
3rd generation



David Cooke  
4th generation



Philip Cooke  
4th generation



Tim Cooke  
5th generation

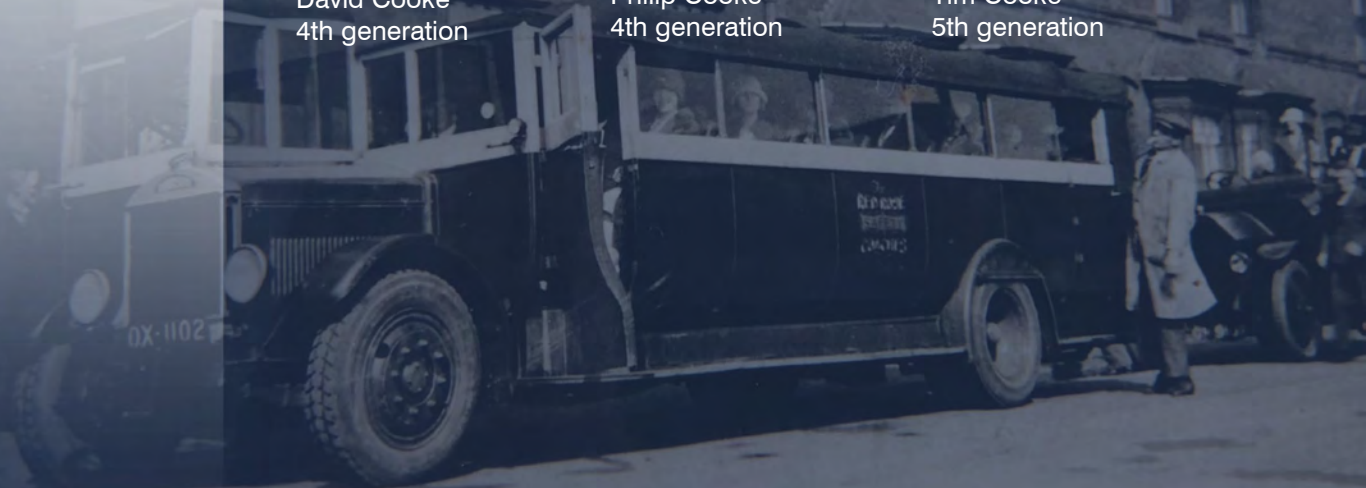

# Cooke Brothers History

## Product History

Cooke Brothers and its own **Phoenix** brand has developed greatly from its early beginnings in 1872. From 1872 through to the 1960's the main market was the cabinet and furniture products. During the 1960's and 1970's the company started to manufacture products for the automotive, off road vehicles (tractors, etc.) and engineering customers.

During the 1970's and 1980's piano hinge ranges were expanded to a full range of engineering continuous hinges. The 1980's also saw greater manufacture of architectural hinges, and through the 1990's and into the 2000's the company added architectural door hardware. During the 2010's through to the present day demand has increased for direct supply to architectural door set manufacturers, as well as on line sales activities to end users.

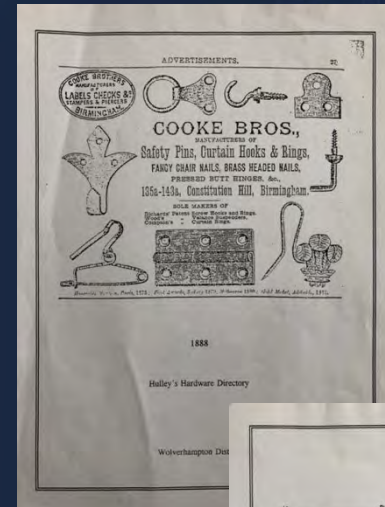

# Cooke Brothers History

Internationally renowned

Cooke Brothers has both exhibited and exported products globally, right from our early beginnings in the late 19<sup>th</sup> century.

Cooke Brothers exhibited internationally at events such as the Paris Exposition Universelle (1889), the Melbourne International Exhibition (1880), the Adelaide Exhibition (1881) and the Sydney International Exhibition (1879).

Their products won awards and medals in Paris, Sydney, Melbourne and Adelaide, going as far back as 1879.

The company has successfully continued to trade internationally and has sustained a strong commitment to export.

Recent projects include the M+ Museum (Hong Kong), the Palm Residence (Dubai), the Grand Lisboa Palace, Macau and Hong Kong International Airport.

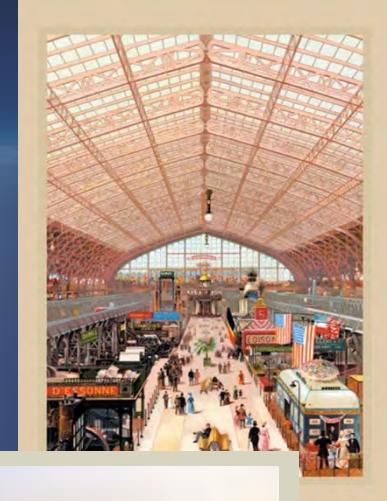
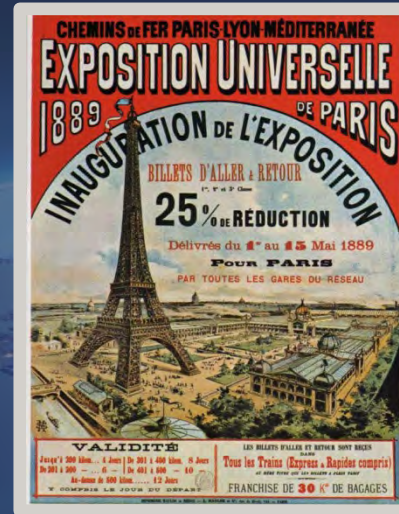

# Cooke Brothers

## Main product categories & Phoenix branded products

### Product Summary

- Hinges
- Door hardware
- Door systems
- Shelf support systems

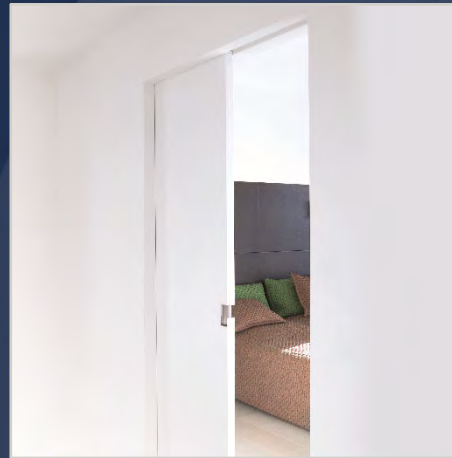

# Cooke Brothers Products - Hinges

- Architectural Butt Hinges
- Continuous Hinges
- Concealed Hinges
- Engineering Hinges

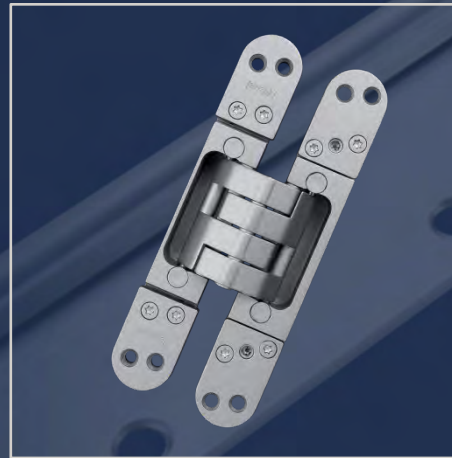

# Cooke Brothers

## Products – Architectural Butt Hinges

### Different Bearing Systems

- Loadmaster
- Concealed bearing
- Slimline thrust washer
- Shrouded bearing
- Washered knuckle
- Plain knuckles

### Different Styles

- Butt Hinges
- Lift Off Hinges
- Special Function Hinges



## Cooke Brothers Products – Continuous Hinges

- Light duty continuous hinges
- Medium duty continuous hinges
- Heavy duty continuous hinges
- Architectural continuous hinges

Cooke Brothers also offer a cut to length service on continuous hinges

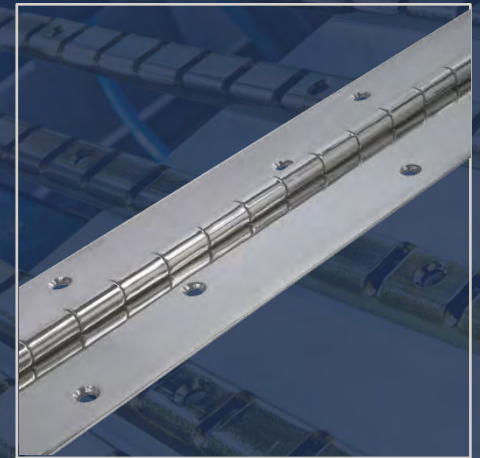

# Cooke Brothers

## Products – Concealed Hinges

- Light duty
- Medium duty
- Heavy duty
- Self closing
- For use with cladding
- For glass doors
- Power assisted

Concealed hinges give your door a seamless appearance with clean lines, uninterrupted by protruding hinge knuckles. They're the ideal choice both in terms of creating a modern, sleek look and maximising safety and security. With no protruding hinges the door system offers anti-burglary and reduced ligature benefits.

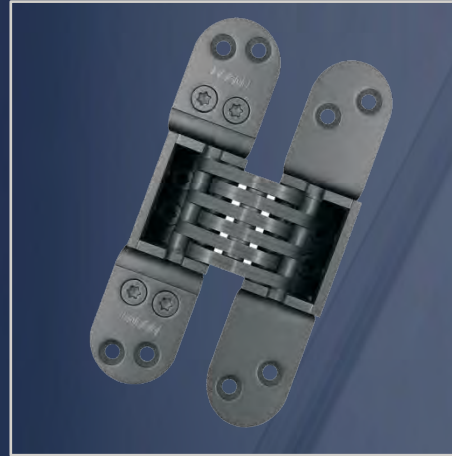

# Cooke Brothers Products – Engineering Hinges

- Modular Hinges
- Marine Hinges
- Polymer Cabinet Hinges
- Functional hinges



# Cooke Brothers Products – Door Hardware

- Door selectors
- Pivot sets
- Push and kick plates
- Vision panels
- Letter plates
- Inset handles
- Door edge protection
- Flush bolts

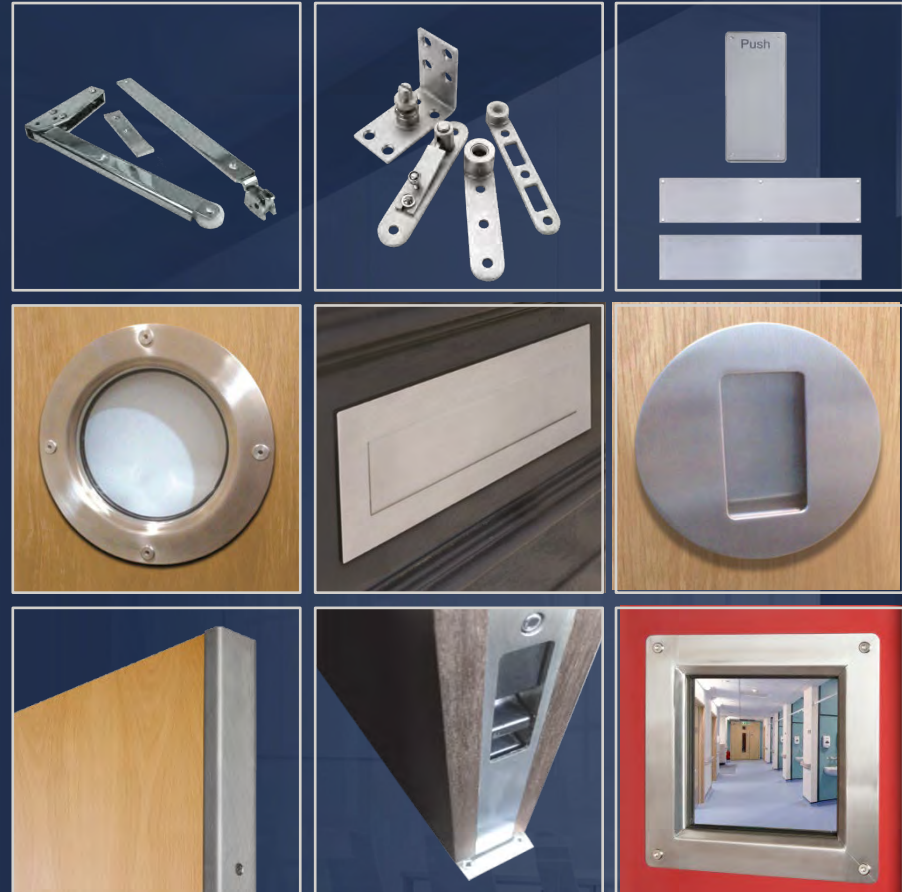

# Cooke Brothers

## Bespoke products

In-house laser cutting and punching capabilities allows Cooke Brothers to provide its customers with a comprehensive and flexible service, which includes:

- Small one-off production batches, including single product prototyping
- Minimal, and often zero, tooling costs
- Rapid design changes
- Low cost and low 'single piece' prices
- Express delivery

We have modern secondary operation presses with 100 tonnes capacity, ideal for lower volume production of complex shapes. With ancillary equipment for riveting, drilling, welding, tapping, finishing and folding,



# Cooke Brothers Bespoke Services

## Manufacturing capability

Cooke Brothers internal manufacturing capability can all be offered as a bespoke service to meet customers specific needs.

- Multi function laser punch press
- Robotic welding
- Hydraulic and power presses
- CNC machining
- EDM hole sparking
- Welding
- Assembly
- Finishing, including plating, coating, polishing



# Cooke Brothers

## Technical Capabilities

### Technical customer support

- Product design
- Research and development
- Quality assurance
- Testing
- Warehousing and despatch

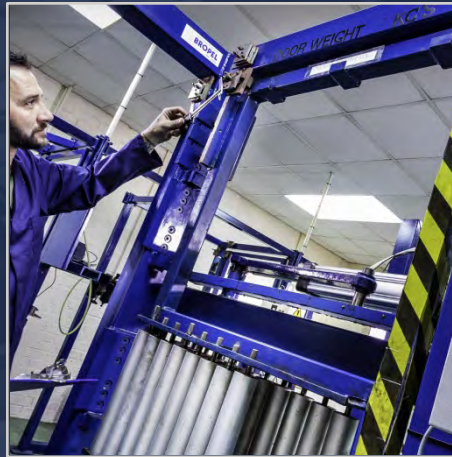

# Cooke Brothers

## Accreditations

### In-house test cell

- EN1935 shear, overload & endurance
- Abuse & severe duty testing

### Independent testing and accreditation

- Salt-spray corrosion resistance
- ISO9001
- Investors in People Silver Standard
- Certifire & CE Marking of Architectural Door Hinges

### Federations and memberships

- Made in the Midlands
- Guild of Architectural Ironmongers
- Door & Hardware Federation



certifire



# Cooke Brothers Routes to supply

- Direct to OEM producers
- Via Distributors and Retailers
- Through customer own branding and packaging
- Through On line purchase

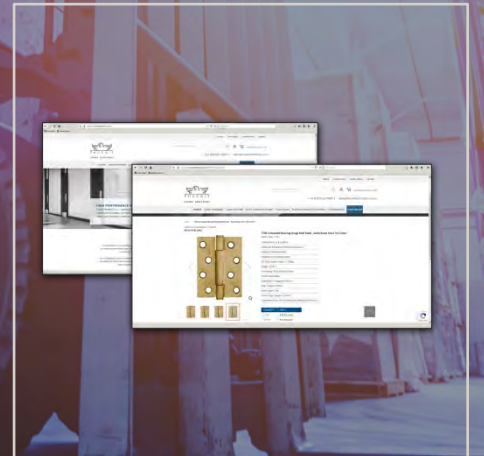

Cooke Brothers  
Contact - Meet the team



**Tim Cooke**  
Managing Director  
DDI 01922 740001  
Mobile 07825 537293  
timc@cookebrothers.co.uk



**Hayley Small**  
DipGAI, MInstAI, RegAI  
Sales Office Manager  
DDI 01922 740011  
hayley@cookebrothers.co.uk



**Dean Moriarty**  
Production Manager  
DDI 01922 740025  
Mobile 07554 452494  
deanm@cookebrothers.co.uk



Tool design and  
manufacturers

Areas of expertise

Process flow

Capabilities



# Phoenix Tooling Overview

30 Years of expertise in tool making and manufacturing

Established in 1990, Phoenix Tooling and Development Ltd has progressively built up a solid reputation for high quality precision press tooling,

Phoenix work for a wide range of industries including world class Automotive, Aerospace, White Goods and Electronics companies. The company has achieved a well-earned status for its specialist expertise in Progression, Transfer and Multi-Slide tooling.

Phoenix Tooling's expertise and proven performance has enabled the company to build a wide portfolio of satisfied customers and a universal seal of approval from many of the world's leading machinery manufacturers.

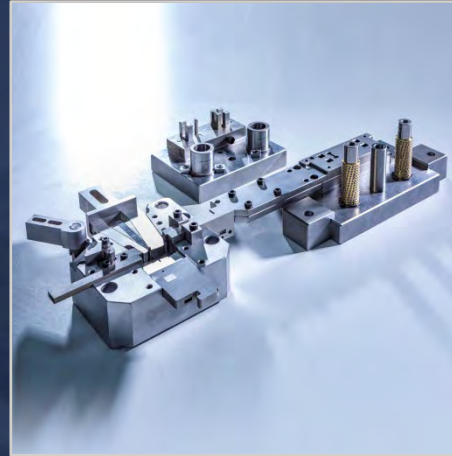

# Phoenix Tooling

## Areas Of Expertise

### Multi-slide tooling

40 Years experience in designing and manufacturing multi-slide tooling.

### Progression tooling

High quality, durable and reliable progression tool solutions. Press requirements from 10 to 1000 tons

### Sub assembly tooling

Proven skills and experience to professionally handle the complete tooling process through to final assembly

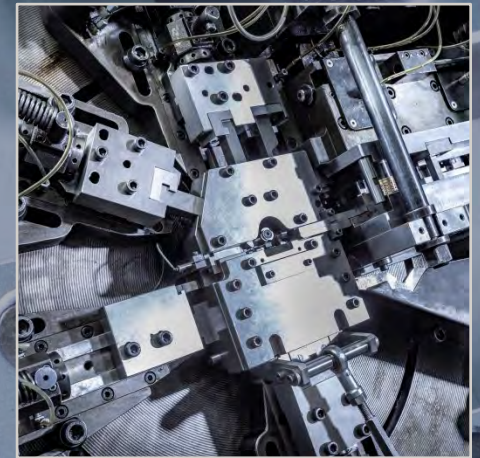

# Phoenix Tooling

## Areas Of Expertise

### Jigs and fixtures

Design and manufacture of jigs and fixtures, such as welding fixtures, assembly jigs, special purpose rigs, etc

### Turnkey packages

The team at Phoenix have the ability, together with their world leading partnerships, to manage and deliver full turnkey metal pressing solutions.

### Prototype tooling

All processes, on site, from 3D design, CNC manufacture, CNC laser cutting, pressing capacity up to 300 ton and the latest laser scanning



# Phoenix Tooling

## Process Flow – From Concept to Reality

### Project planning

Comprehensive capacity planning, ensuring accurate and realistic lead-times

### Tool design

Utilising our state of the art 3D CAD software.

### Manufacture

Phoenix has the ability and capacity to carry out sub-contract machining services including 2D and 3D soft and hard machining, surface grinding and high precision EDM wire eroding.

### Assembly

The company can provide dedicated assembly areas, over-head cranes, multiple assembly areas and a coordinated workforce



# Phoenix Tooling

## Process Flow – From Concept to Reality

### Tool try-out

Comprehensive capacity planning, ensuring accurate and realistic lead-times

### Tool development

Utilising our state of the art 3D CAD software.

### Commissioning

Phoenix has the ability and capacity to carry out sub-contract machining services including 2D and 3D soft and hard machining, surface grinding and high precision EDM wire eroding.

### Measuring

The company can provide dedicated assembly areas, over-head cranes, multiple assembly areas and a coordinated workforce



# Phoenix Tooling Capabilities

- Press Tool Consultancy
- Component Simulation
- 3D Tool Design
- Tool Manufacture
- Press Tool Repairs
- Press Tool Modifications
- Laser Cutting / Punch Press Services
- CMM Services
- Machining 2D & 3D
- Wire Eroding
- Presswork – Small or Large Batch Runs
- Multi-Slide Presswork
- Romer Arm Laser Scanning / Reverse Engineering
- Press Tool Servicing
- Prototype Manufacture
- Jig & Fixture Manufacture
- Project Management of Far Eastern Tooling Packages
- Tooling TPM Management
- Bespoke Turn-Key Packages

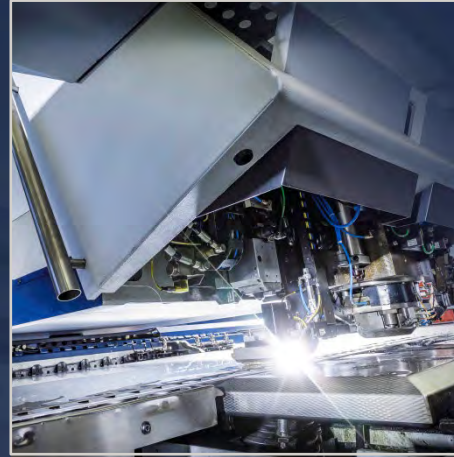

Phoenix Tooling  
Contact - Meet the team



**Martin Mulvey**  
Managing Director  
martin.mulvey@phoenixtooling.co.uk  
T. 07554 452487



**Peter Marshall**  
Operations Director  
peter.marshall@phoenixtooling.co.uk  
T. 07880 038580



**David Burgess**  
Design Manager  
david.burgess@phoenixtooling.co.uk  
T. 01922 743414



T: +44 (0)1922 740011    E: [sales@cookebrothers.co.uk](mailto:sales@cookebrothers.co.uk)    W: [cookebrothers.co.uk](http://cookebrothers.co.uk)

Cooke Brothers Ltd, Northgate, Aldridge, Walsall, West Midlands, WS9 8TL, United Kingdom